

Specifications:

Impedance:	50 $\Omega$
Frequency range:	0 ... 2 GHz
Return loss:	$\geq 25$ dB, DC ... 1GHz $\geq 15$ dB, 1 ... 2GHz
Insertion loss:	$\leq 0,15$ dB
Insulation resistance:	$\geq 5 \times 10^3$ M $\Omega$
Center contact resistance:	$\leq 3.0$ m $\Omega$ 10-32 side, $\leq 1.5$ m $\Omega$ BNC side
Outer contact resistance:	$\leq 3.0$ m $\Omega$ 10-32 side, $\leq 1.0$ m $\Omega$ BNC side
Test voltage:	1000 V rms
Working voltage:	400V rms
Contact current:	$\leq 3$ A typ.
Mating cycles:	500 matings
Temperature range:	-55°C to +155°C

*Materials / Plating:*

Body:	CuZn / Flash white bronze over silver
Center contact:	CuBe / Au, min. 0,8 $\mu$ m, over Ni
Outer contact:	CuZn / Flash white bronze over silver
Dielectric:	PTFE
Gasket:	Silicone

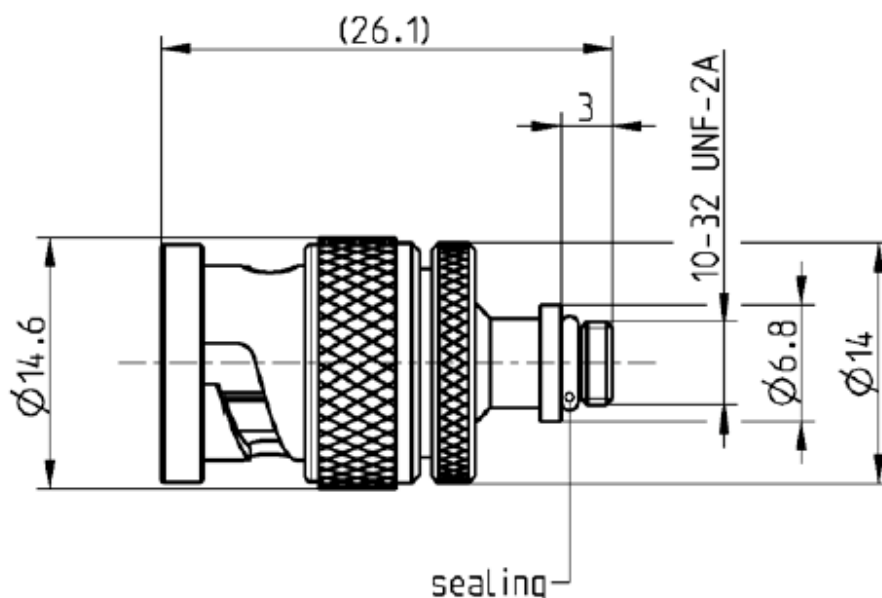

While the information in this datasheet has been carefully compiled to the best of our knowledge, nothing is intended as representation of warranty on our part and no statement herein shall be construed as recommendation to infringe existing patents. In the effort to improve our products, we reserve the right to make changes judged to be necessary.