

Specifications:

Impedance:	50 Ω
Frequency range:	0 ... 10 GHz
Return loss:	≥ 33 dB, DC ... 2,5GHz ≥ 30 dB, 2,5 ... 6GHz
Insertion loss:	$\leq 0,15$ dB
Insulation resistance:	$\geq 5 \times 10^3$ M Ω
Center contact resistance:	$\leq 1,5$ m Ω
Outer contact resistance:	≤ 1.0 m Ω
Test voltage:	1500 V rms
Working voltage:	400V rms
Power handling:	≤ 80 W @ 2GHz
Mating cycles:	Min. 500 matings
Center contact captivation: axial	≥ 15 N
Temperature range:	-55°C to +155°C

Materials / Plating:

Body:	CuZn / Flash white bronze over silver
Center contact:	CuZn / Au, min. 0,8 μ m, over Ni
Outer contact:	CuZn / Flash white bronze over silver
Dielectric:	PTFE
Gasket:	NeopreneCR 50C6

Suitable cable(s): 11-RJV30/61R-N1

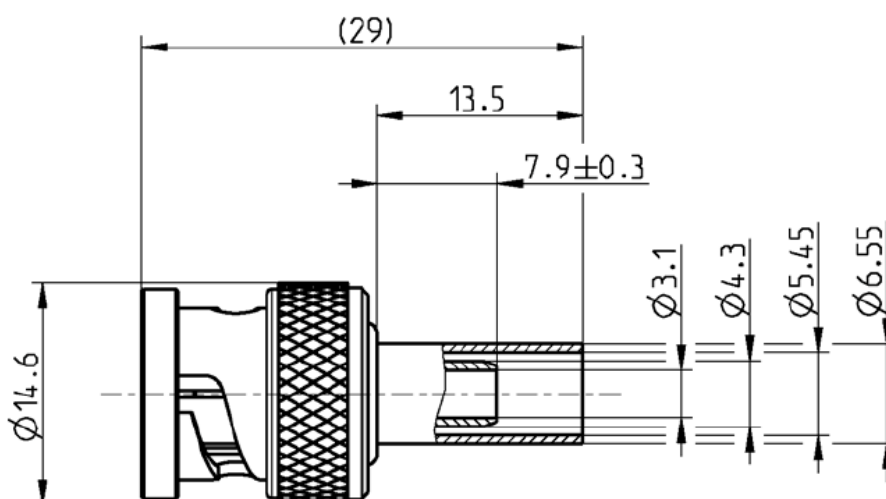

While the information in this datasheet has been carefully compiled to the best of our knowledge, nothing is intended as representation of warranty on our part and no statement herein shall be construed as recommendation to infringe existing patents. In the effort to improve our products, we reserve the right to make changes judged to be necessary.